

Vermatic clamps

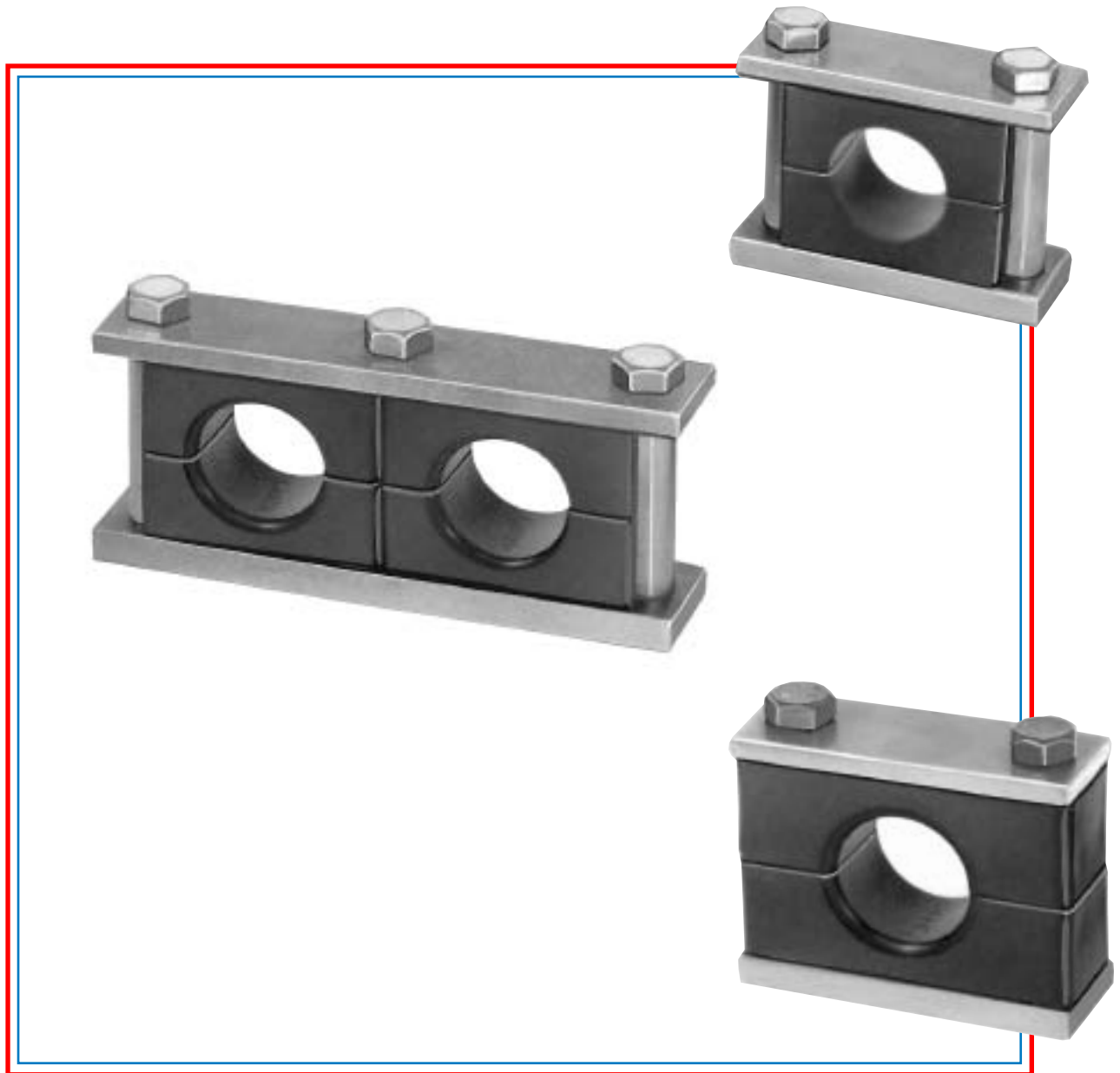

Single or multiple clamp
assemblies for tube, pipe or hose.



Clamp Assemblies for Pipes, Tubes and Hoses

Vermatic cushion-clamp assemblies are a simple, reliable system that reduce shock and vibration caused by fluid surges in pipes, tubes, and hoses used in both mobile and stationary industrial applications.

The Vermatic cushion eliminates metal-to-metal contact on piping installations. The solid cushion design resists crushing while absorbing shock and suppressing vibration and noise. The cushions are composed of a high impact copolymer with exceptional toughness, low temperature impact resistance, and long life to temperatures of +220° F. The polypropylene remains stable in applications subjected to light acids, solvents, fuels, mineral oils, alcohol, paints, and salt water.

The quality steel hardware can be weld or channel mounted for fast and easy installation, or cushions are available for your own mounting design. The standard series clamps have a controlled grip feature as the post prevents over squeezing and distortion of the tube, pipe, or hose during installation.

Clamp assemblies are available for steel tubing sizes from 1/4 to 6 inch O.D., steel piping sizes from 1/8P to 6P, and hose sizes from 1/2 to 3 inch O.D.

Vermatic Products, Inc. is in business to support your business. We have twenty years of experience in manufacturing high quality pipe, tube, and hose clamps and our specialty is service. Small minimum orders and same day emergency shipping are features to assist you in meeting your production requirements. In addition to our standard product line, we have several specialized products available upon request that can be tailored to suit your needs. There are options for super heavy duty applications and special combinations of multilevel stacking arrangements. Consult the factory for additional information.

With Vermatic's policy of constantly improving its products, specifications are subject to change without notice.

Vermatic, Incorporated
1785 S. Johnson Road
New Berlin, WI 53146
www.vermatic.com

(262) 513-9384
(800) 922-6461
Fax (262) 513-9403

Pipe Tube and Hose Clamps The Choice of Many Industries

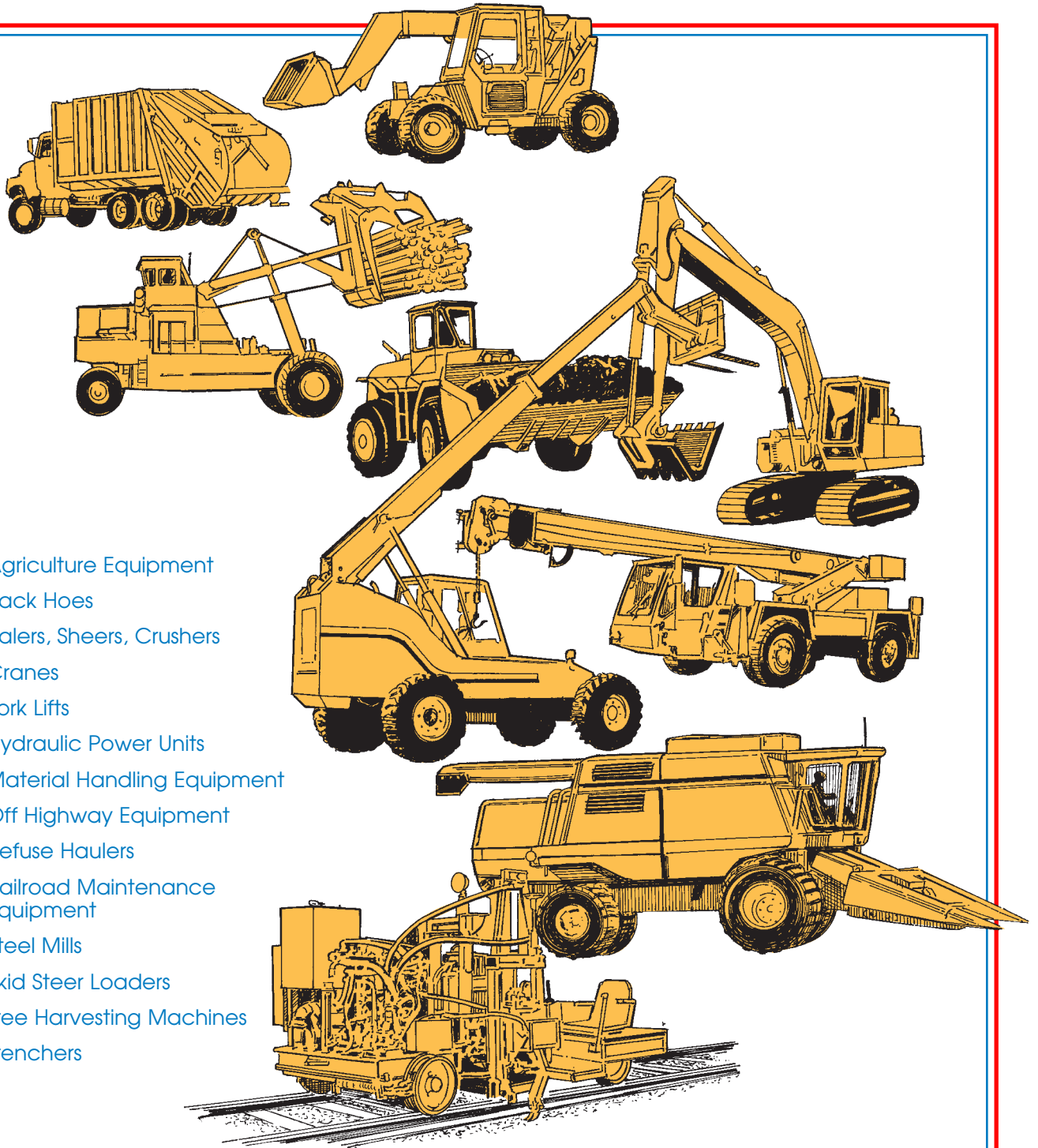

- Agriculture Equipment
- Back Hoes
- Balers, Sheers, Crushers
- Cranes
- Fork Lifts
- Hydraulic Power Units
- Material Handling Equipment
- Off Highway Equipment
- Refuse Haulers
- Railroad Maintenance Equipment
- Steel Mills
- Skid Steer Loaders
- Tree Harvesting Machines
- Trenchers

Vermatic clamps



HOSE CUSHION

SPECIALIZED COMBINATIONS



TABLE OF CONTENTS

PAGES

Introduction

2

Applications

3

Standard Series

Weld and Channel Mount
Post Fastener
Open End Cushion
One to Six Unit Clamp

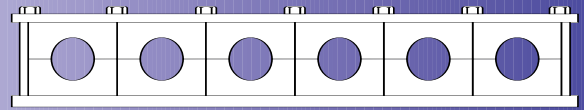
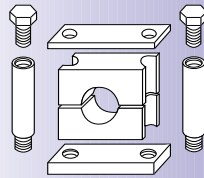

6-9

100 Series

Weld and Channel Mount
Button Fastener
Closed End Cushion
One or Two Unit Clamp

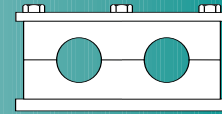
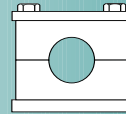
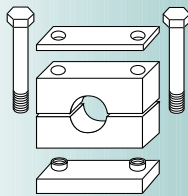

10-13

200 Series

Weld and Channel Mount
One Bolt, Button Fastener
Closed End Cushion
Two or Four Unit Clamp

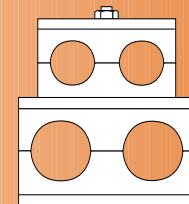
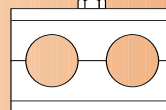
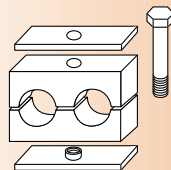

14-15

400 Series

Weld and Channel Mount
Post Fastener
Closed End Cushion
One or Two Unit Clamp

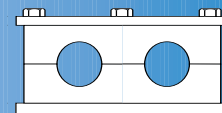
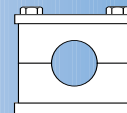
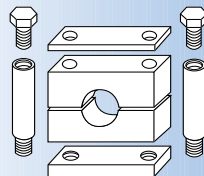

16-17

600 Series

Channel Mount
Channel Nut Fastener
Closed End Cushion
One or Two Unit Clamp

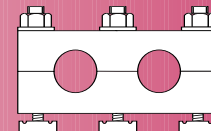
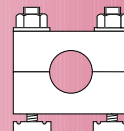
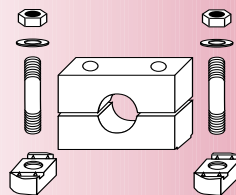

18-19

STANDARD SERIES



STANDARD SERIES

SHORT BASE MOUNT

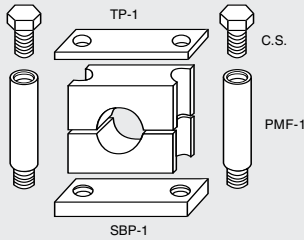

BASE MOUNT

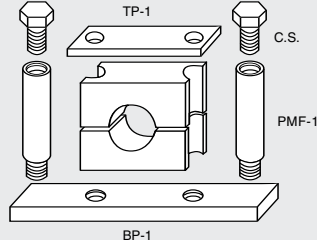

CHANNEL MOUNT

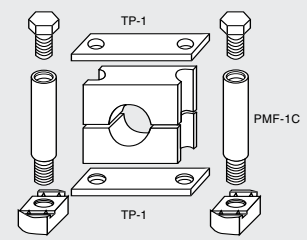

DIMENSIONS IN INCHES

SERIES	DIMENSIONS IN INCHES											
	B	C	D	E	F	J	L	P	R	T	W	X
3	.312	1.250	.375	.250	-	-	1.000	.125	.875	.125	1.000	1/4 - 20
5	.312	1.500	.375	.250	-	-	1.330	.125	.875	.125	1.000	1/4 - 20
10	.437	1.875	.500	.312	.937	.750	1.437	.125	.875	.187	1.000	3/8 - 16
15	.500	2.500	.625	.375	1.250	1.000	1.900	.250	.875	.250	1.250	7/16 - 14
20	.500	3.000	.625	.375	1.250	1.250	2.400	.250	.875	.250	1.250	7/16 - 14
25	.500	3.500	.625	.375	1.250	1.500	2.925	.250	.875	.250	1.250	7/16 - 14
30	.625	4.250	.750	.500	-	-	3.600	.375	.875	.375	1.750	1/2 - 13
35	.625	4.750	.750	.500	-	-	4.000	.375	.875	.375	1.750	1/2 - 13
45	.625	5.750	.750	.500	-	-	5.000	.375	.875	.375	1.750	1/2 - 13
50	1.000	6.750	1.000	.625	-	-	6.375	-	.875	.375	1.750	3/4 - 10
60	1.000	7.750	1.000	.625	-	-	7.375	-	.875	.375	1.750	3/4 - 10

ENGINEERING DATA

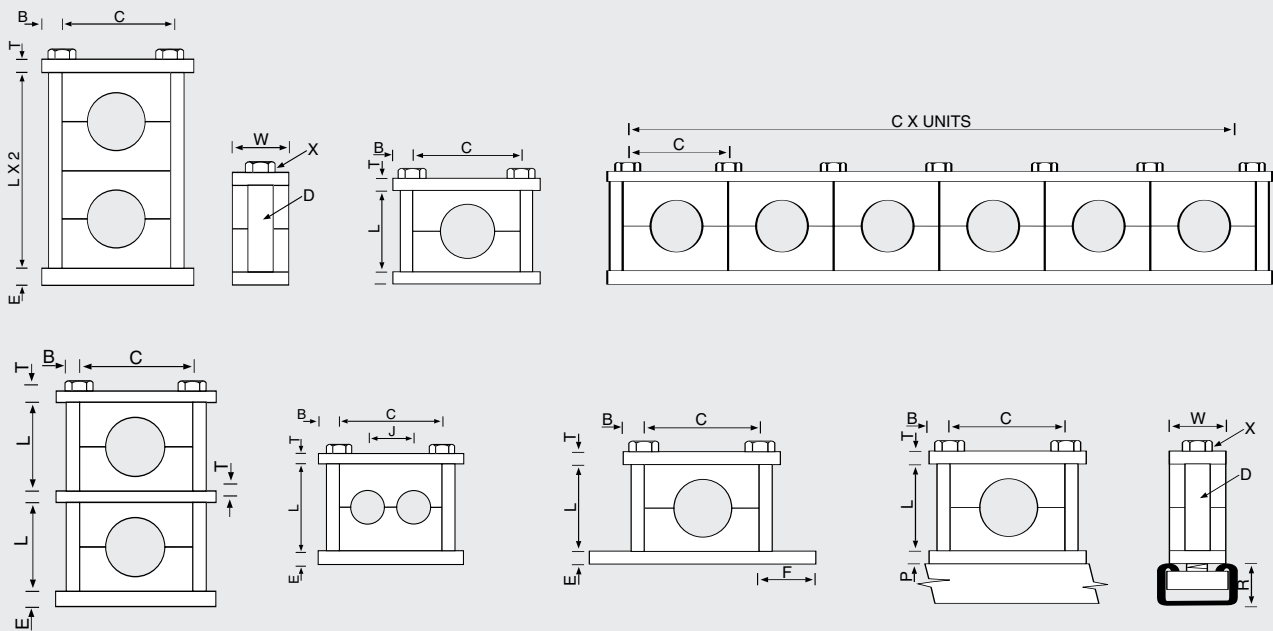

STANDARD SERIES

CUSHION SIZES

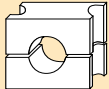
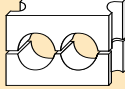
BO R E	S E R I E S					
		TUBE O.D.	PIPE SIZE	HOSE O.D.	TWIN SELECT 2 SIZES	
1/4	3	.250 .375 .500 .625 .750	1/8P 1/4P 3/8P	.500H .562H .625H .687H .750H		
1/4	5	.250 .375 .500 .625 .750 .875 1.000	1/2P 3/4P	.750H .812H .875H .937H 1.000H		
3/8	10	.500 .625 .750 .875 1.000 1.250	1/8P (.405) 1/4P (.540) 3/8P (.675) 1/2P (.840) 3/4P (1.050)	.625H .687H .750H .812H .875H .937H 1.000H 1.062H 1.125H 1.187H	.250 .375 .500	
7/16	15	.750 1.000 1.250 1.500	1P (1.315) 1-1/4P (1.660)	1.062H 1.125H 1.187H 1.250H 1.312H 1.375H 1.437H 1.500H	.375 .500 .625 .750	.562H 1/4P .625H 3/8P .687H .750H
7/16	20	1.500 1.750 2.000	1-1/4P (1.660) 1-1/2P (1.900)	1.562H 1.625H 1.687H 1.750H 1.812H 1.875H 1.937H 2.000H	.750 .875 1.000	1/2P .750H 3/4P .812H .875H .937H 1.000H
7/16	25	2.000 2.250 2.500	2P (2.375)	2.062H 2.125H 2.187H 2.250H 2.312H 2.375H 2.437H 2.500H	.750 .875 1.000 1.250	1/2P .750H 3/4P .812H .875H .937H 1.000H
1/2	30	2.500 3.000	2-1/2P (2.375)	2.562H 2.625H 2.687H 2.750H 2.812H 2.875H 2.937H 3.000H		
1/2	35	3.000 3.500	3P (3.500)			
1/2	45	4.000 4.500	4P (4.500)			
3/4	50	5.000 5.500	5P (5.563)			
3/4	60	6.000	6P (6.625)			

STANDARD SERIES

CHANNEL MOUNT

MODEL NUMBER

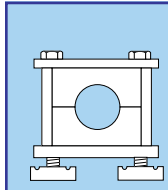

3-C-1
5-C-1
10-C-1
15-C-1
20-C-1
25-C-1
30-C-1
35-C-1
45-C-1

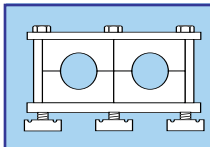

3-C-2
5-C-2
10-C-2
15-C-2
20-C-2
25-C-2

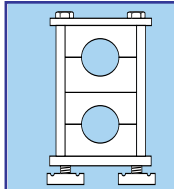

3-C-1-1
5-C-1-1
10-C-1-1
15-C-1-1
20-C-1-1
25-C-1-1

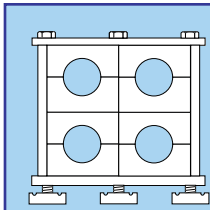

3-C-2-2
5-C-2-2
10-C-2-2
15-C-2-2
20-C-2-2
25-C-2-2

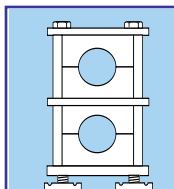

10-CX-1-1
15-CX-1-1
20-CX-1-1
25-CX-1-1
30-CX-1-1

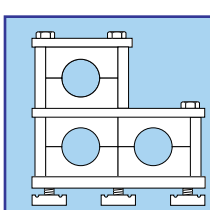

10-CX-2-1
15-CX-2-1
20-CX-2-1
25-CX-2-1

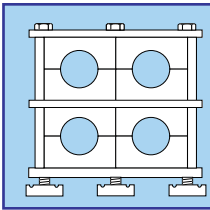

10-CX-2-2
15-CX-2-2
20-CX-2-2
25-CX-2-2

Product Configurations & Ordering Information

FOR COMPLETE MODEL NUMBER:

1. Determine your series from cushion size chart, 3, 5, 10, 15, 20, 25, 30, 35, 45, 50, 60.
2. Select clamp model number.
3. Add Cushion size to clamp model number.
4. Clamp prices include tube, pipe or hose cushions.
5. Select hose cushion sizes that are closest to hose O.D.
6. 15, 20 & 25 series may be channel mounted in longer than 2 units. Consult factory.

Examples...

3-SB-1-R-.687H
5-SB-2-R-1.000-.750
10-SB-4-R-.750Hx2-1.000Hx2
20-C-1-R-1.750H
25-SB-1-R-2P

Consult factory for clamp options.

WELD MOUNT

MODEL NUMBER

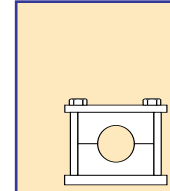

3-SB-1
5-SB-1
10-SB-1
15-SB-1
20-SB-1
25-SB-1
30-SB-1
35-SB-1
45-SB-1
50-SB-1
60-SB-1

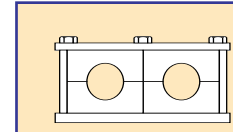

3-SB-2
5-SB-2
10-SB-2
15-SB-2
20-SB-2
25-SB-2

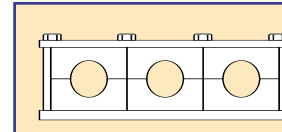

3-SB-3
5-SB-3
10-SB-3
15-SB-3
20-SB-3
25-SB-3

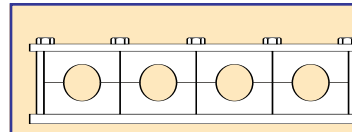

3-SB-4
5-SB-4
10-SB-4
15-SB-4
20-SB-4
25-SB-4

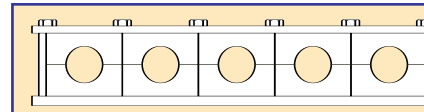

3-SB-5
5-SB-5
10-SB-5
15-SB-5

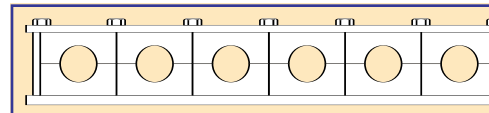

3-SB-6
5-SB-6
10-SB-6
15-SB-6

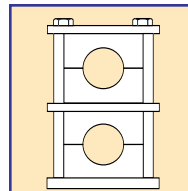

10-SBX-1-1
15-SBX-1-1
20-SBX-1-1
25-SBX-1-1
30-SBX-1-1
35-SBX-1-1
45-SBX-1-1

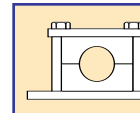

10-B-1
15-B-1
20-B-1
25-B-1

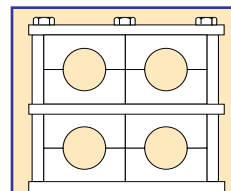

10-SBX-2-2
15-SBX-2-2
20-SBX-2-2
25-SBX-2-2

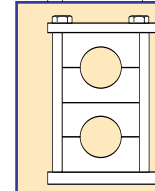

3-SB-1-1
5-SB-1-1
10-SB-1-1
15-SB-1-1
20-SB-1-1
25-SB-1-1

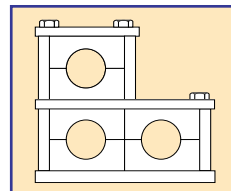

10-SBX-2-1
15-SBX-2-1
20-SBX-2-1
25-SBX-2-1

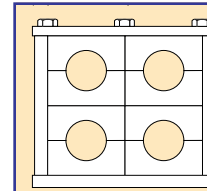

3-SB-2-2
5-SB-2-2
10-SB-2-2
15-SB-2-2
20-SB-2-2
25-SB-2-2

100 SERIES

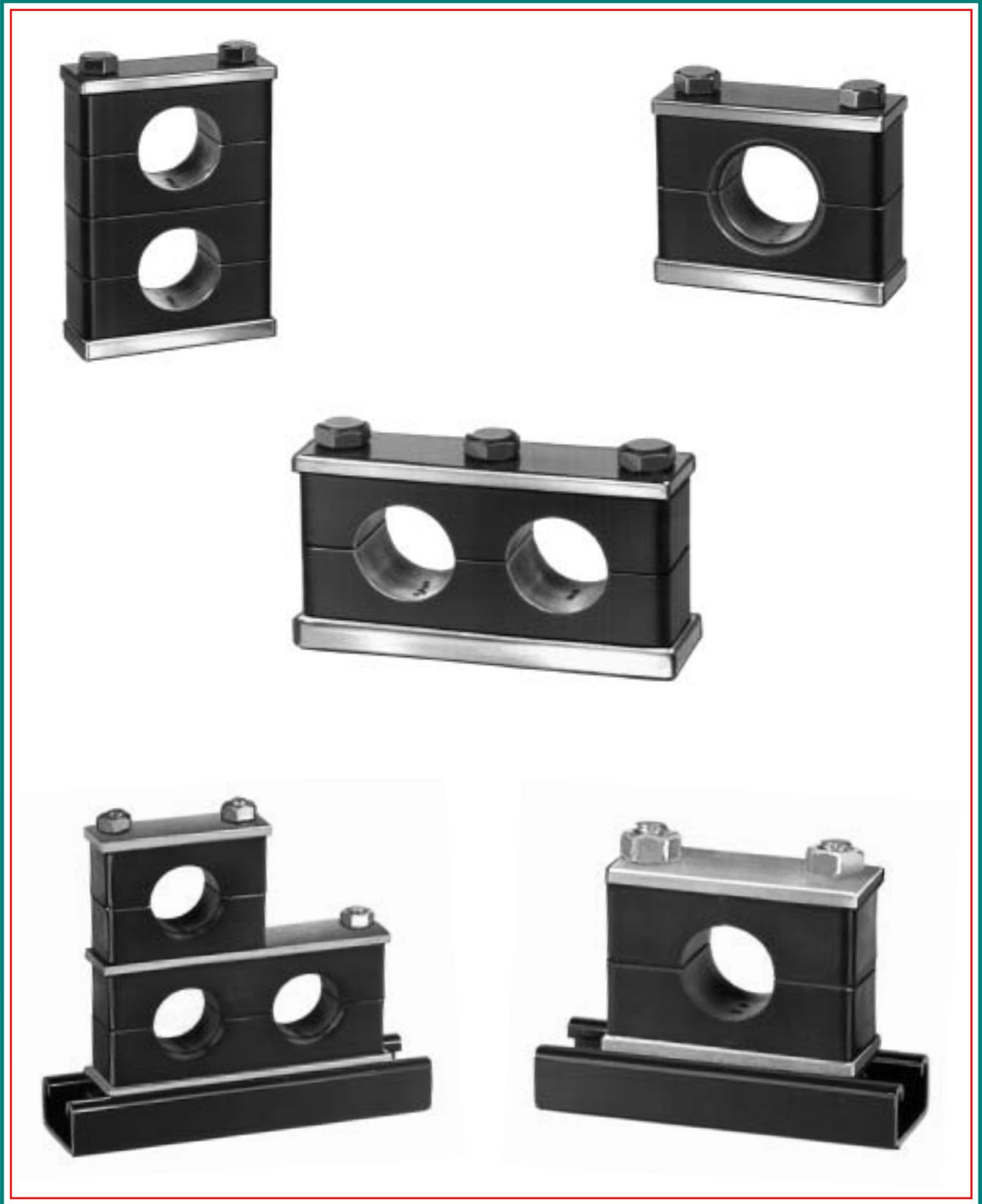

100 SERIES

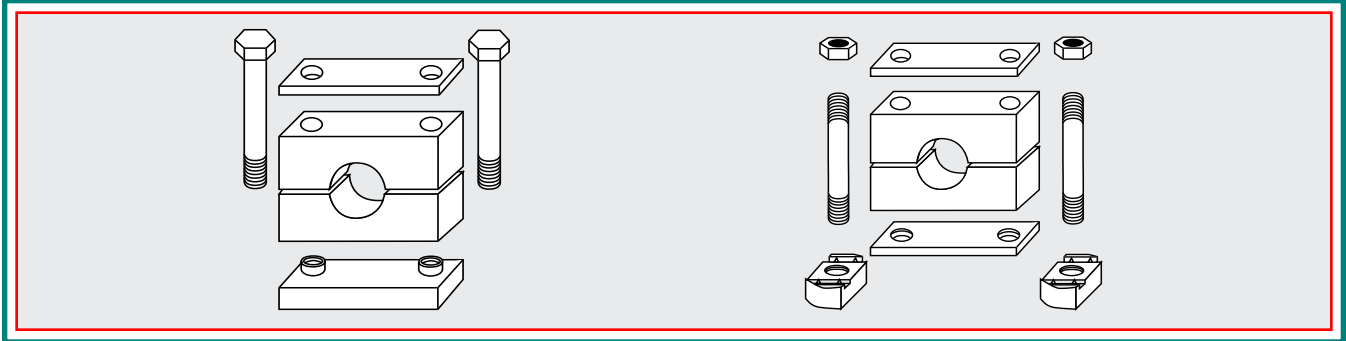

SERIES	DIMENSIONS IN INCHES								
	E	T	C	H	R	L	B	W	X
103	.312	.187	1.250	.125	1.250	1.000	.375	1.000	$\frac{5}{16}$ - 18
104	.312	.187	1.750	.125	1.250	1.000	.375	1.000	$\frac{5}{16}$ - 18
105	.312	.187	1.500	.125	1.250	1.250	.375	1.000	$\frac{5}{16}$ - 18
107	.312	.187	2.000	.125	1.250	1.850	.375	1.000	$\frac{5}{16}$ - 18
115	.375	.250	2.500	.250	1.250	2.125	.500	1.250	$\frac{7}{16}$ - 14
120	.375	.250	3.000	.250	1.250	2.625	.500	1.250	$\frac{7}{16}$ - 14
125	.375	.250	3.500	.250	1.250	3.125	.500	1.250	$\frac{7}{16}$ - 14

ENGINEERING DATA

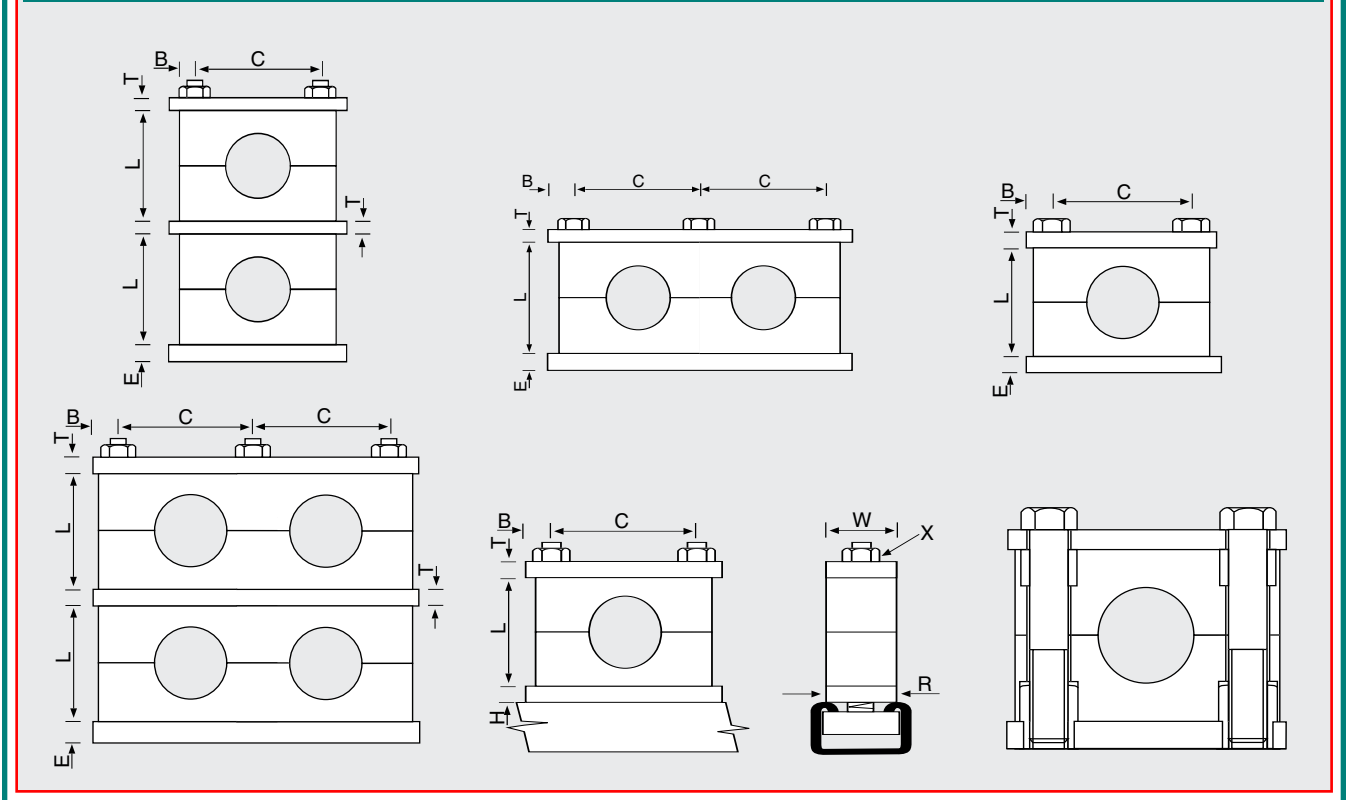

100 SERIES CUSHION SIZES

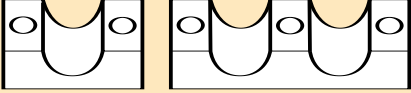
BOLT REF	SERIES			
		TUBE O.D.	PIPE SIZE	HOSE O.D.
5/16	103	.250	1/8P	.500H
		.375		.562H
		.500	1/4P	.625H
		.625		.687H
		.750	3/8P	.750H
5/16	104	.250x2	1/8P x 2	
		.375x2		
		.500x2	1/4P x 2	
5/16	105	.250		.750H
		.375	1/2P	.812H
		.500		.875H
		.625	3/4P	.937H
		.750		1.000H
5/16	107	.750	1/2P	1.062H
		.875		1.125H
		1.000	3/4P	1.187H
		1.250		1.250H
		1.500	1P	1.312H
				1.375H
7/16	115			1.437H
				1.500H
		.750	1/2P	1.062H
		.875		1.125H
		1.000	3/4P	1.187H
		1.250	1P	1.250H
7/16	120	1.500	1-1/4P	1.312H
		1.750		1.375H
		2.000	1-1/2P	1.437H
		2.250		1.500H
		1.000	3/4P	1.562H
		1.250	1P	1.625H
7/16	125	1.500	1-1/4P	1.687H
		1.750		1.750H
		2.000	1-1/2P	1.812H
		2.250		1.875H
		2.500	2P	1.937H
				2.000H
7/16	125	1.500	3/4P	2.062H
		1.750	1P	2.125H
		2.000	1-1/4P	2.187H
		2.250	1-1/2P	2.250H
		2.500	2P	2.312H
			2-1/2P	2.375H
		2.437H		
		2.500H		

100 SERIES

Clamp Assemblies for Tube, Pipe or Hose

Product Configurations & Ordering Information

For Complete Model Number:

1. Determine your clamp series from cushion size chart, 103, 104, 105, 107, 115, 120, 125.
2. Select clamp model number.
3. Add Cushion size to clamp model number.
4. Clamp prices include tube, pipe or hose cushions.
5. Select hose cushion sizes that are closest to hose O.D.

Examples

105-SB-1-R-3/4P
 107-CX-1-1-R-1.187H-1.187H
 115-SBX-1-1-R-1.250-1.500
 125-C-1-R-2P
 Consult factory for clamp options.
 Note: 104-SB-1 clamps 2 tubes or pipe.

MODEL NUMBER

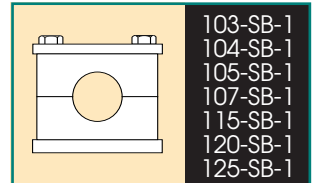

WELD MOUNT

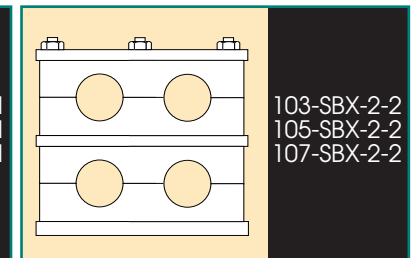
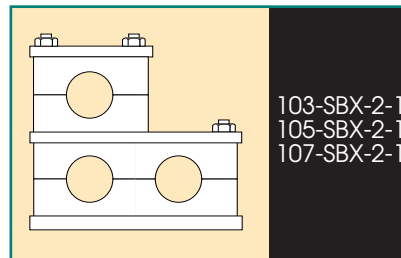
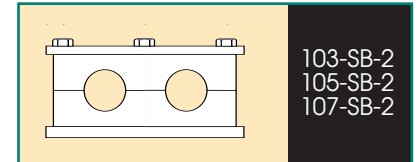
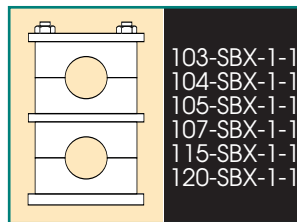

CHANNEL MOUNT

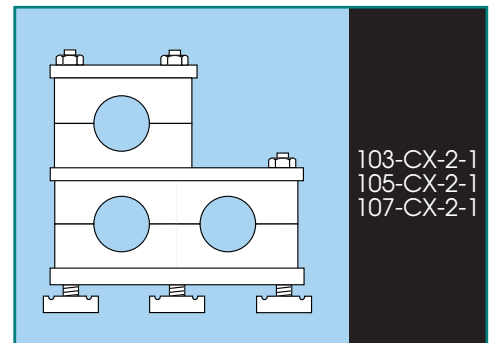
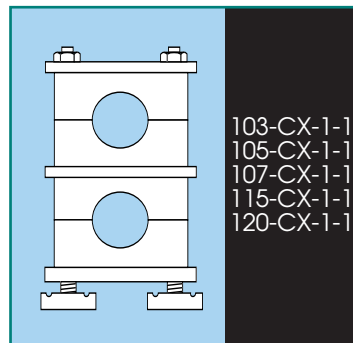
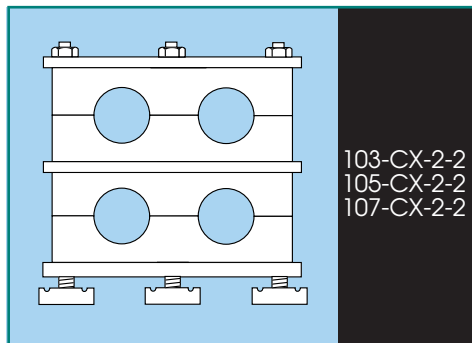
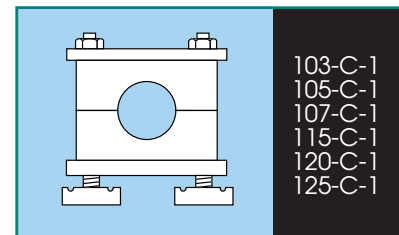
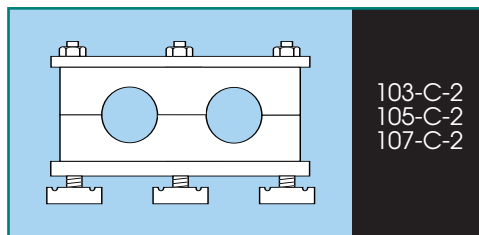

200 SERIES

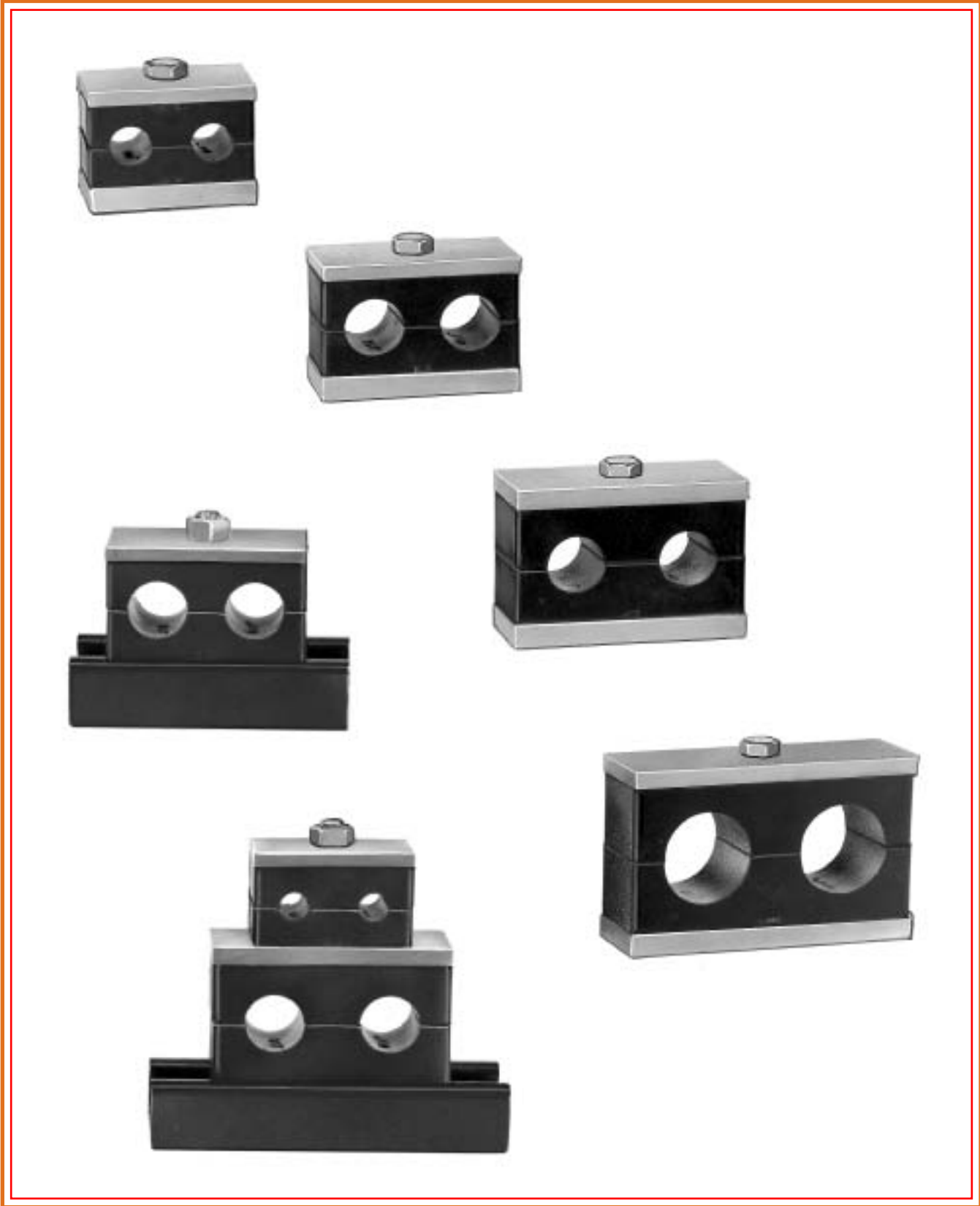

200 SERIES

CUSHION SIZES

BOLT TYPE	S E R I E S			
		TUBE O.D.	PIPE SIZE	HOSE O.D.
5/16	201	.250		
		.375		
		.500		
5/16	203	.250	1/8P	.500H
		.375	1/4P	.562H
		.500	3/8P	.625H
		.625		.687H
5/16	205	.375	3/8P	.750H
		.500		.812H
		.625	1/2P	.875H
		.750		.937H
		.875		
5/16	207	1.000		1.000H
		.750	1/2P	1.062H
		.875		1.125H
		1.000	3/4P	1.187H
		1.250	1P	1.250H
		1.500		1.312H
			1.375H	
			1.437H	

Product Configurations & Ordering Information

For Complete Model Number:

1. Determine your series from cushion size chart, 201, 203, 205, 207.
2. Select clamp model number.
3. Add Cushion size to clamp model number.
4. Clamp prices include tube, pipe or hose cushions.
5. Select hose cushion sizes that are closest to hose O.D.

Examples
 201-W-2-R-.375-.375
 203-203-W-2-2-R-.500X2-.750X2
 205-203-C-2-2-R-1.000X2-.750X2
 207-205-W-2-2-R-1.250X2-1.000X2

CHANNEL MOUNT	MODEL NUMBER	WELD MOUNT	MODEL NUMBER
	201-C-2 203-C-2 205-C-2 207-C-2		201-W-2 203-W-2 205-W-2 207-W-2
	201-201-C-2-2 203-201-C-2-2 203-203-C-2-2 205-201-C-2-2 205-203-C-2-2 205-205-C-2-2 207-201-C-2-2 207-203-C-2-2 207-205-C-2-2 207-207-C-2-2		201-201-W-2-2 203-201-W-2-2 203-203-W-2-2 205-201-W-2-2 205-203-W-2-2 205-205-W-2-2 207-201-W-2-2 207-203-W-2-2 207-205-W-2-2 207-207-W-2-2

ENGINEERING DATA

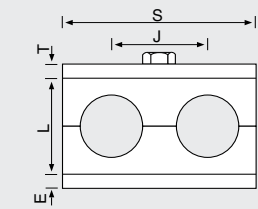

SERIES	DIMENSIONS IN INCHES						
	E	T	S	J	L	W	X
201	.312	.187	2.000	1.000	1.000	1.250	5/16 - 18
203	.312	.187	2.500	1.250	1.250	1.250	5/16 - 18
205	.312	.250	3.000	1.500	1.500	1.250	5/16 - 18
207	.312	.250	4.000	2.000	2.000	1.250	5/16 - 18

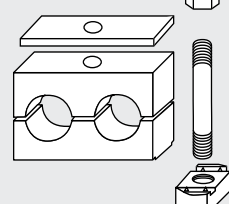
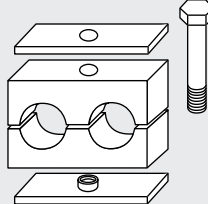
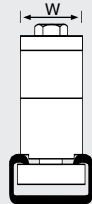
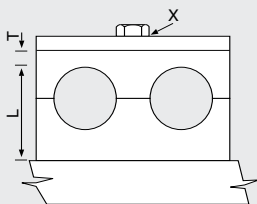
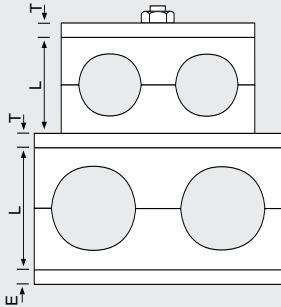

400 SERIES

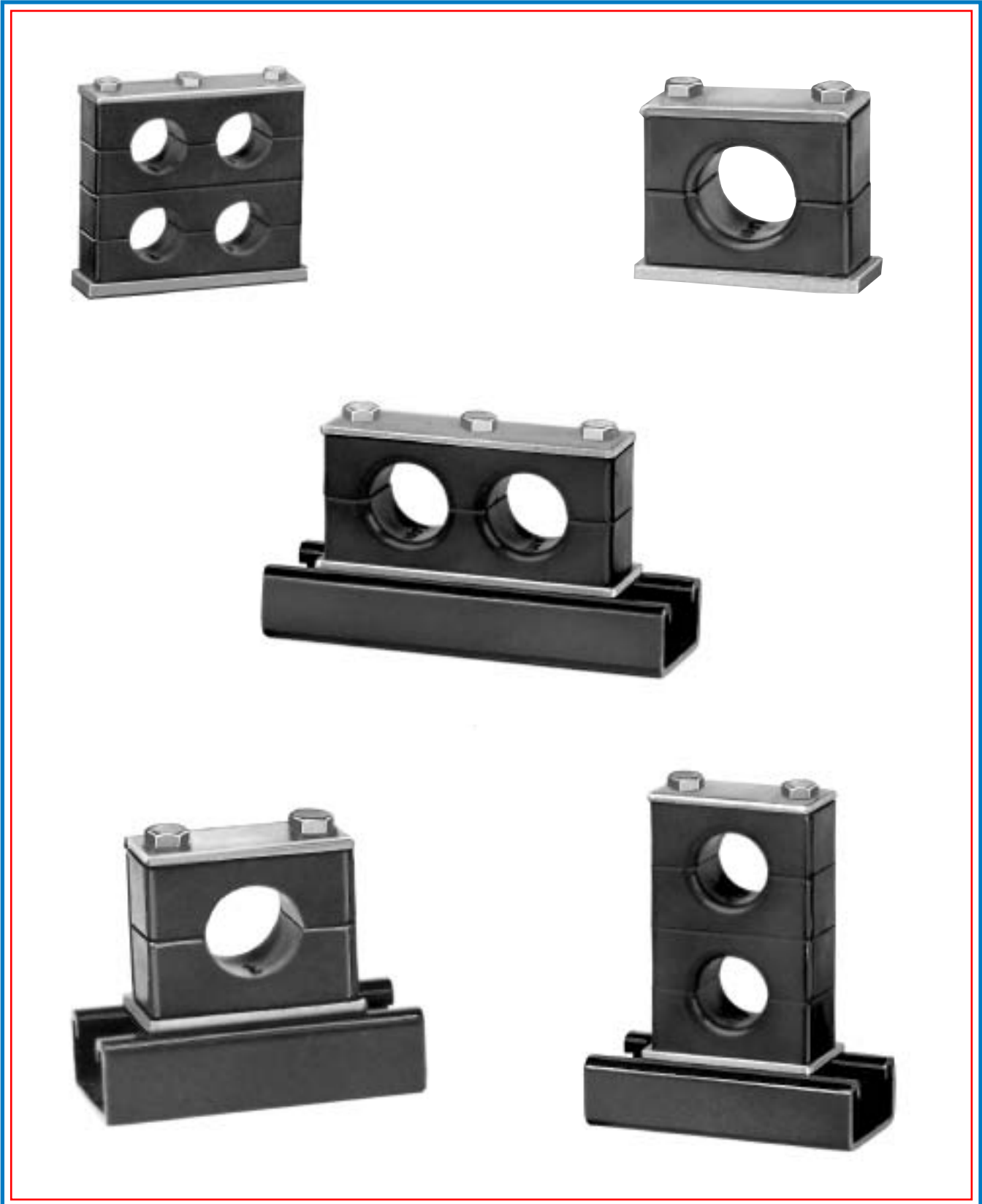

400 SERIES

CUSHION SIZES

BORE	SERIES	CUSHION SIZES		
		TUBE O.D.	PIPE SIZE	HOSE O.D.
1/4	403	.250	1/8P	.500H
		.375		.562H
		.500	1/4P	.625H
		.625	3/8P	.687H
		.750		.750H
1/4	405	.375	1/2P	.750H
		.500		.812H
		.625		.875H
		.750		.937H
		.875		
1.000	3/4P	1.000H		
1/4	407	.750	1/2P	1.062H
		.875		1.125H
		1.000		1.187H
		1.250	3/4P	1.250H
		1.500	1P	1.312H
				1.375H
				1.437H
		1.500H		

PRODUCT CONFIGURATIONS & ORDERING INFORMATION

Clamp Assemblies for Tube, Pipe or Hose

For Complete Model Number:

1. Determine your clamp series from cushion size chart, 403, 405, or 407.
2. Select clamp model number.
3. Add Cushion size to clamp model number.
4. Clamp prices include tube, pipe or hose cushions.
5. Select hose cushion sizes that are closest to hose O.D.

Examples...

403-SB-1-R-.625
 405-C-2-R-1/2P-3/4P
 405-C-2-2-R-1.000X2-1.000X2
 Consult factory for clamp options.

WELD MOUNT

MODEL NUMBER

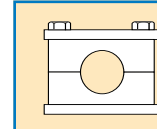

403-SB-1
 405-SB-1
 407-SB-1

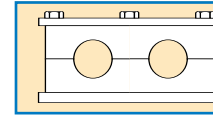

403-SB-2
 405-SB-2
 407-SB-2

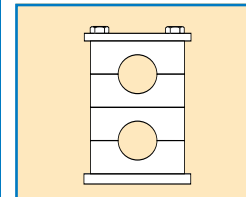

403-SB-1-1
 405-SB-1-1

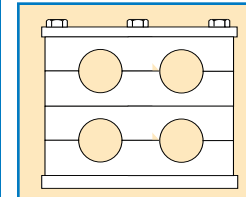

403-SB-2-2
 405-SB-2-2

CHANNEL MOUNT

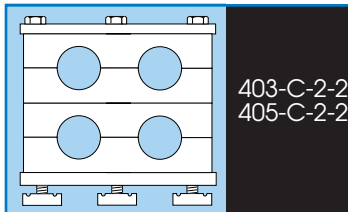

403-C-2-2
 405-C-2-2

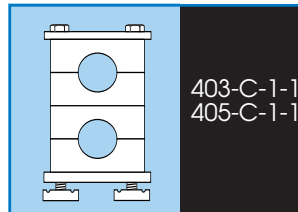

403-C-1-1
 405-C-1-1

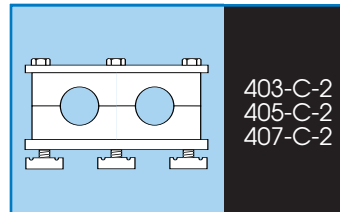

403-C-2
 405-C-2
 407-C-2

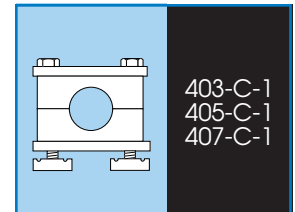

403-C-1
 405-C-1
 407-C-1

ENGINEERING DATA

SERIES	DIMENSIONS IN INCHES								
	E	T	C	B	H	L	P	W	X
403	.250	.125	1.250	.312	1.250	1.000	1.625	1.000	1/4 - 20
405	.250	.125	1.500	.312	1.250	1.500	1.625	1.000	1/4 - 20
407	.250	.125	2.000	.375	1.250	1.875	1.625	1.000	1/4 - 20

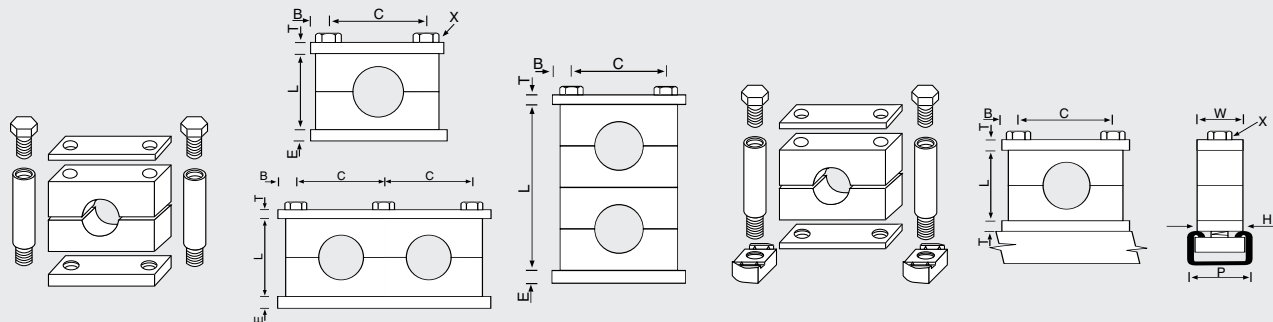

600 SERIES



CUSHIONS ONLY

CUSTOMER MOUNTING SURFACE →

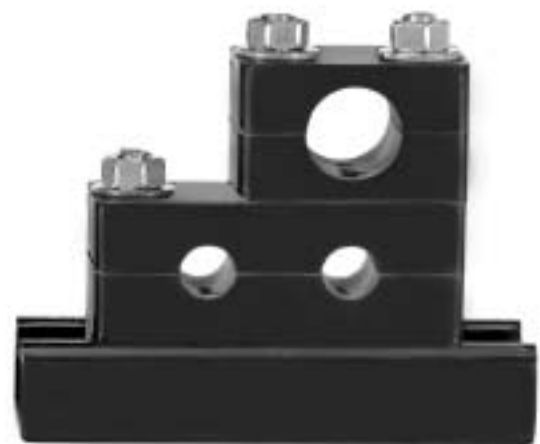

OPTIONAL TOP PLATES AVAILABLE FOR 600 SERIES.

600 SERIES

PRODUCT CONFIGURATIONS & ORDERING INFORMATION

CUSHION SIZES

BOLT REF	SERIES	CUSHION SIZES		
		TUBE O.D.	PIPE SIZE	HOSE O.D.
5/16	603	.250	1/8P	.500H
		.375		.562H
		.500	1/4P	.625H
		.625		.687H
		.750	3/8P	.750H
5/16	605	.375		.750H
		.500	1/2P	.812H
		.625		.875H
		.750	3/4P	.937H
		.875		1.000H
5/16	607	.750	1/2P	1.062H
		.875		1.125H
		1.000	3/4P	1.187H
		1.250		1.250H
		1.500	1P	1.312H
			1.437H	
			1.500H	

CHANNEL MOUNT

Clamp Assemblies for Tube, Pipe or Hose

Light to Medium duty applications

For Complete Model Number:

1. Determine your clamp series from cushion size chart, 603, 605, 607.
2. Select clamp model number.
3. Add Cushion size to clamp model number.
4. Clamp prices include tube, pipe or hose cushions.
5. Select hose cushion sizes that are closest to hose O.D.

Examples...
 603-C-1-R-625
 605-C-2-R-1/2P-3/4 P
 607-C-1-1-R-1.125H-1.125H
 Consult factory for clamp options.

Cushions only can be supplied for customers own mounting

MODEL NUMBER

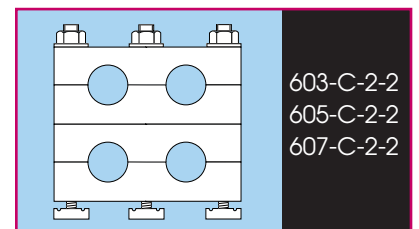
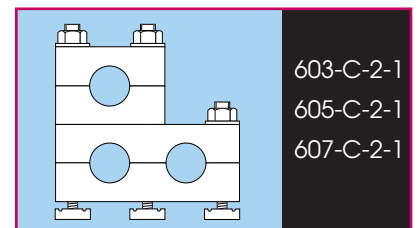
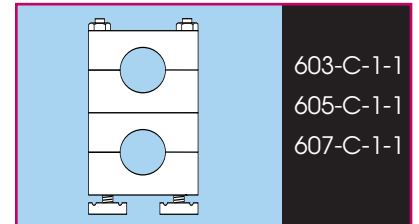
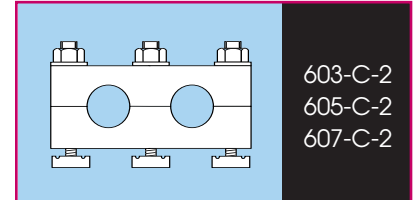
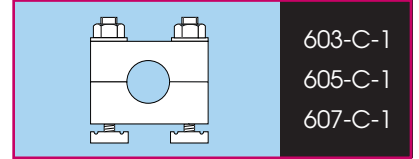

ENGINEERING DATA

SERIES	DIMENSIONS IN INCHES				
	B	C	L	W	X
603	.375	1.250	1.250	1.250	5/16 - 18
605	.375	1.500	1.500	1.250	5/16 - 18
607	.375	2.000	2.000	1.250	5/16 - 18

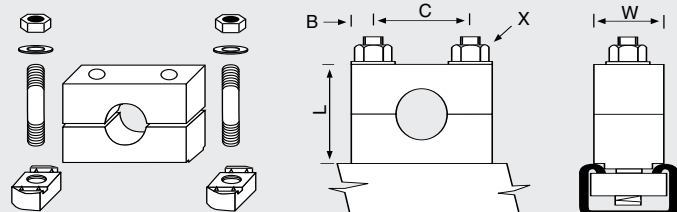

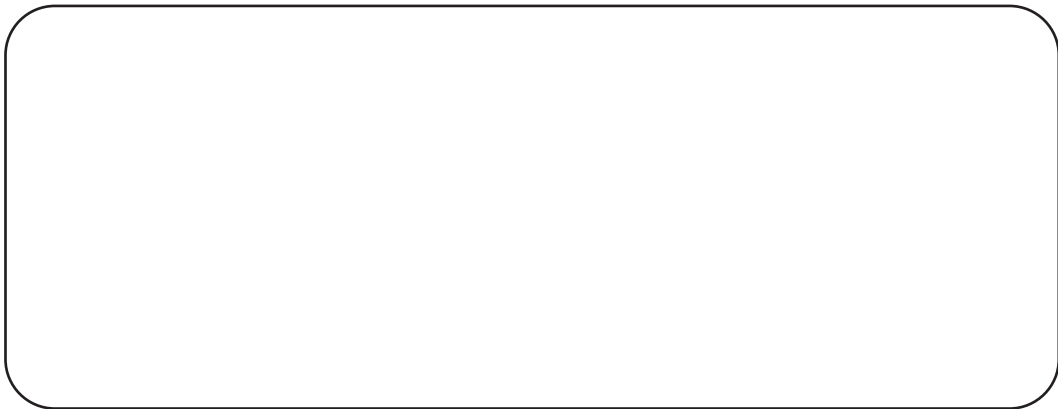
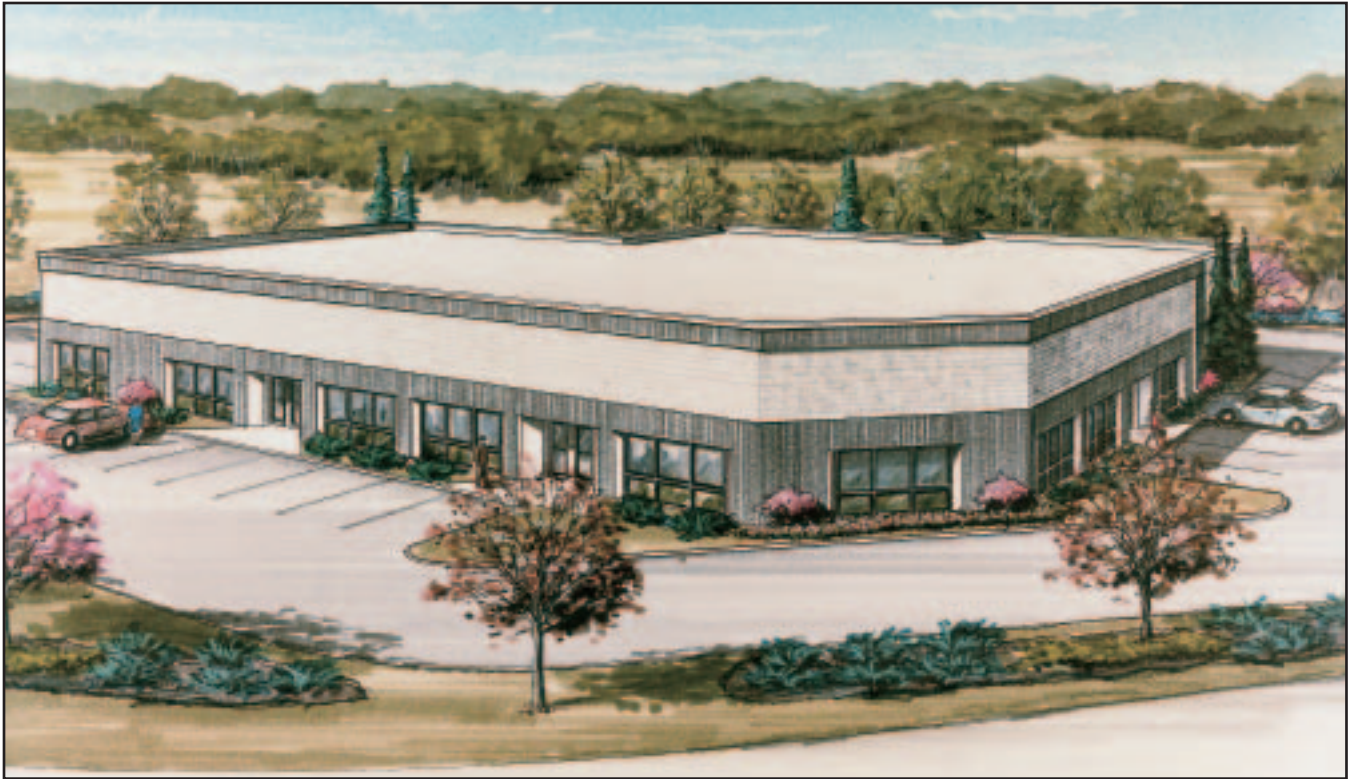

No. V4049